

## Höhenverstelltisch Elevator Stage

**HVM 60**

9012.0034

Ausgabe 27.09.2007

- |   |   |
|---|---|
| <ul style="list-style-type: none"> <li>• geringe Bauhöhe</li> <li>• Hub bis 12 mm</li> <li>• industrietauglich</li> <li>• hochfeste Aluminium-Legierung</li> <li>• vorgespannte Kreuzrollführungen</li> <li>• berührungslose, hochgenaue Endschalter (Hall-Sensoren)</li> <li>• mit Schritt- oder DC-Servomotor</li> </ul> <p>Option</p> <ul style="list-style-type: none"> <li>• Vakuumausführungen lieferbar</li> </ul> | <ul style="list-style-type: none"> <li>• low height</li> <li>• travel up to 12 mm</li> <li>• designed for industrial applications</li> <li>• high strength aluminium alloy</li> <li>• preloaded cross roller guides</li> <li>• contactless, high-precision limit switches (Hall sensors)</li> <li>• with step or DC servo motor</li> </ul> <p>Option</p> <ul style="list-style-type: none"> <li>• versions for use in vacuum available</li> </ul> |
|---|---|

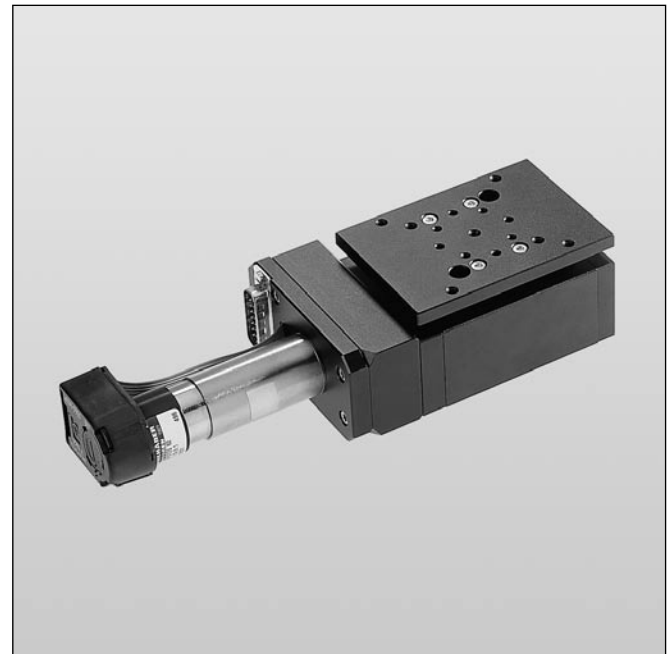

Die bewährten Höhenverstellische HVM 60 zeichnen sich durch eine niedrige Bauhöhe und eine hohe Wiederholgenauigkeit aus. Die vorgespannten Führungen sorgen für praktisch ruckfreien Lauf sowie für hohe Belastbarkeit. Alle Aluminiumteile haben eine hochwertige schwarze Eloxal-Schutzschicht.

The proven elevator stages of the HVM 60 series have a low height and a high repeatability. The special guides provide practically slip-stick free movement as well as high load capacity. All aluminium parts have a top-quality black anodized protective coating.

### Bestellangaben/Ordering Information

Höhenverstelltisch elevator stage	mit Schrittmotor with step motor		mit DC-Servomotor with DC servomotor	
Hub/travel	Typ/type	Bestell-Nr./part no.	Typ/type	Bestell-Nr./part no.
12 mm	HVM 60-12-HSM	42.060.016C	HVM 60-12-HDS	42.060.011C

### Zubehör/Accessories

Sonderfett, 5 ml im Applikator	special grease, 5 ml, in applicator	SST.F11	90.999.0011
--------------------------------	-------------------------------------	---------	-------------

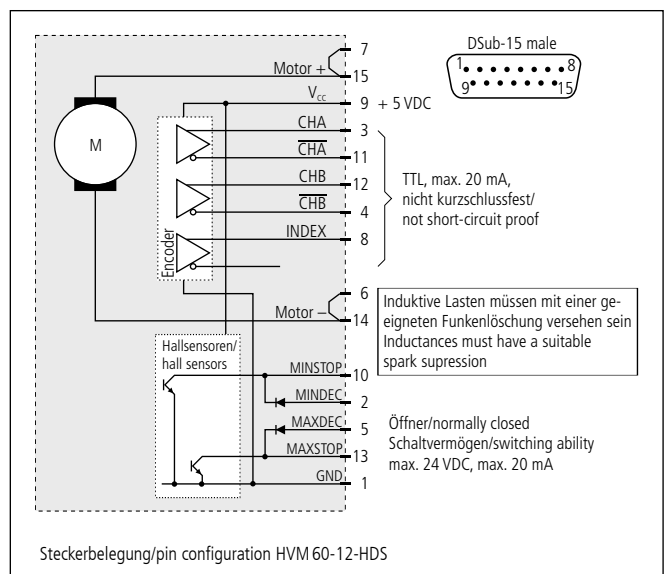
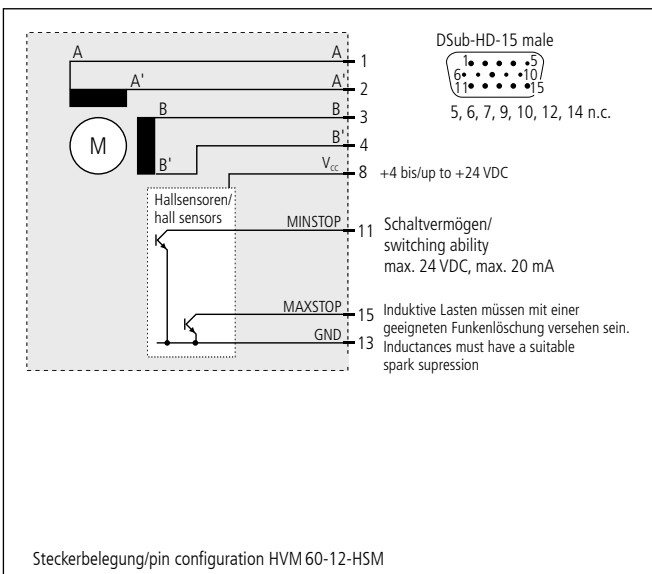
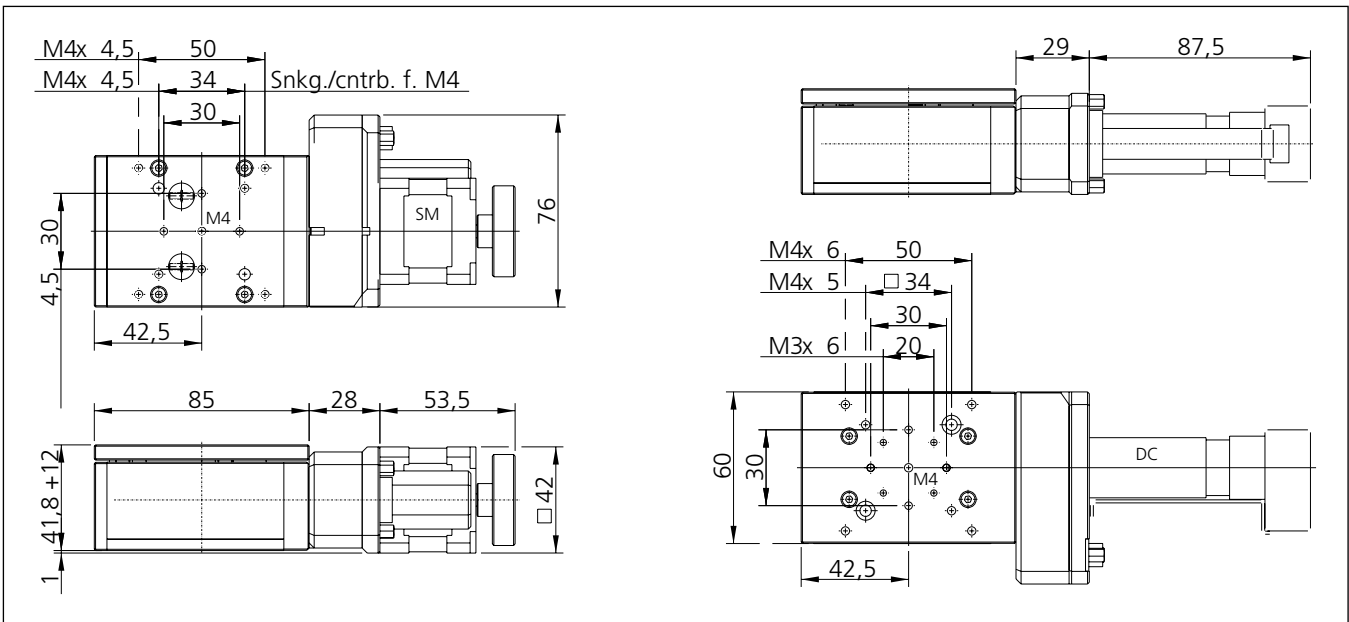

**Technische Daten/Technical Data HVM 60** (bei 20 °C/@20 °C, ohne Last/no load)

		Schrittmotor step motor	DC-Servomotor DC servo motor	
Hub	travel		12	mm
Geschwindigkeit	velocity	max. 6	max. 0,5	mm/s
Tragkraft	load capacity		max. 90	N
Kippmoment (Mx, My)	moment of tilt (Mx, My)		max. 0,5	Nm
Kippmoment (Mz)	moment of tilt (Mz)		max. 1,5	Nm
Wiederholfehler (bidirektional)	repeatability (bidirectional)		<6	µm
Positionierfehler	positioning error		<80	µm
Gierwinkel	yaw angle		<170	µrad
Nickwinkel	pitch angle		<170	µrad
Seitenschlag	lateral deviation		<10	µm
Motor-Betriebsspannung	motor voltage	max. 40	max. 12	V
Motor-Haltespannung	holding voltage	2,0	—	V
Motorstrom	motor current	max. 1,8 <sup>1)</sup>	max. 0,49	A
Untersetzung	reduction	—	2401:81	
Hub pro Motorumdrehung	travel per motor rev.	200	6,74719	µm
Schritte/Impulse pro Motorumdr.	steps/pulses per motor rev.	200 <sup>3)</sup>	2000	
Gewicht	weight		~1,0	kg
Betriebsumgebungstemperatur <sup>2)</sup>	ambient operating temperature <sup>2)</sup>		+10 bis/to +50	°C
Lagerungstemperatur <sup>2)</sup>	ambient storage temperature <sup>2)</sup>		-20 bis/to +70	°C

<sup>1)</sup> pro Phase/per phase    <sup>2)</sup> ohne Betauung/without condensation    <sup>3)</sup> im Vollschrittbetrieb/in full-step-mode